



**3DISIS-2021-001**

**Phase 2 Study Report (Rev. 1)**

**08/25/2022**



## Table of Contents

1.0	Summary .....	6
1.1	GI-2021-1 Results .....	6
1.2	GI-2021-2 Results .....	7
1.3	GI-2021-3 Results .....	7
1.4	GI-2021-4 Results .....	7
1.5	GI-2021-6 Results .....	7
1.6	GI-2021-9 Results .....	8
2.0	Introduction .....	9
3.0	Description of the GIRs.....	12
3.1	GI-2021-1 .....	12
3.2	GI-2021-2 .....	12
3.3	GI-2021-3 .....	12
3.4	GI-2021-4 .....	13
3.5	GI-2021-6 .....	13
3.6	GI-2021-9 .....	14
4.0	Study Scope .....	15
4.1	Study Pockets.....	15
4.2	Study Areas .....	15
4.3	Study Criteria.....	16
4.4	Study Methodology .....	17
4.4.1	Transient Stability Study Methodology .....	17
4.4.2	Short-Circuit and Breaker-Duty Study Methodology.....	17
4.5	Study Analyses.....	19
4.6	Southern Colorado Study Pocket Analysis .....	20
4.6.1	Steady-State Analysis.....	20
4.6.2	Transient Stability Analysis.....	24

4.6.3	Short-Circuit Analysis Results .....	26
4.6.4	Summary of Southern Colorado Study Pocket Analysis.....	27
4.7	San Luis Valley Study Pocket Analysis .....	28
4.7.1	Steady-State Analysis.....	28
4.7.2	Transient Stability Analysis.....	28
4.7.3	Short-Circuit Analysis Results .....	29
4.7.4	Summary of San Luis Valley Study Pocket Analysis .....	29
4.8	Northern Colorado Study Pocket Analysis .....	30
4.8.1	Steady-State Analysis.....	30
4.8.2	Transient Stability Results .....	32
4.8.3	Short-Circuit Analysis Results .....	33
4.8.4	Summary of Northern Colorado Study Pocket Analysis .....	35
5.0	Cost Estimates and Assumptions .....	36
5.1	Total Cost of Transmission Provider’s Interconnection Facilities (TPIF) .....	36
5.2	Total Cost of Station Network Upgrades .....	40
5.3	Summary of Generation Interconnection Costs.....	44
5.3.1	For GI-2021-1 .....	44
5.3.2	For GI-2021-2 .....	44
5.3.3	For GI-2021-3 .....	44
5.3.4	For GI-2021-4 .....	45
5.3.5	For GI-2021-6 .....	45
5.3.6	For GI-2021-9 .....	46
5.4	Cost Estimate Assumptions.....	46
6.0	Summary of Generation Interconnection Service .....	48
6.1	GI-2021-1 .....	48
6.2	GI-2021-2 .....	48
6.3	GI-2021-3 .....	48

6.4 GI-2021-4 ..... 49

6.5 GI-2021-6 ..... 49

6.6 GI-2021-9 ..... 50

7.0 Contingent Facilities ..... 51

8.0 Conceptual POI One-Line Diagrams of 3DISIS-2021-001 GIRs ..... 53

9.0 Appendices ..... 57

## List of Figures

Figure 1 – Approximate Locations of 3DISIS-2021-001 Generator Interconnection Request POIs.....	11
Figure 2 – Cost Allocation Calculation.....	19
Figure 3 – Preliminary One-line of the GI-2021-1 POI at the Comanche 230 kV Substation.....	53
Figure 4 – Preliminary One-line of GI-2021-4 69 kV Switching Station tapping the Romeo – Old40Tap 69 kV line.....	54
Figure 5 – Preliminary One-line of the GI-2021-6 230 kV Switching Station tapping the Green Valley – Sky Ranch 230 kV line.....	55
Figure 6 – Preliminary One-line of the GI-2021-9 POI at the Tundra 345 kV Substation.....	56

## List of Tables

Table 1 – Summary of GIRs in the 3DISIS-2021-001.....	10
Table 2 – Southern Colorado Study Pocket ERIS Study Overloads Identified in Single Contingency Analysis.....	21
Table 3 – Southern Colorado Transient Stability Analysis Results.....	24
Table 4 – Short-Circuit Parameters at GI-2021-1 POI.....	26
Table 5 – Short-Circuit Parameters at GI-2021-9 POI.....	26
Table 6 – Heavy Summer and Light Load San Luis Valley Transient Stability Analysis Results.....	28
Table 7 – Short-Circuit Parameters at GI-2021-4 POI.....	29
Table 8 – Northern Colorado Study Pocket ERIS Study Overloads Identified in Single Contingency Analysis.....	31
Table 9 – Northern Colorado Transient Stability Analysis Results.....	32
Table 10 – Short-Circuit Parameters at GI-2021-2 POI.....	33
Table 11 – Short-Circuit Parameters at GI-2021-3 POI.....	34
Table 12 – Short-Circuit Parameters at GI-2021-6 POI.....	34
Table 13 – Total cost of Transmission Provider’s Interconnection Facilities by GIR.....	36
Table 14 – GI-2021-1 Transmission Provider’s Interconnection Facilities.....	37
Table 15 – GI-2021-2 Transmission Provider’s Interconnection Facilities.....	37
Table 16 – GI-2021-3 Transmission Provider’s Interconnection Facilities.....	37
Table 17 – GI-2021-4 Transmission Provider’s Interconnection Facilities.....	38
Table 18 – GI-2021-6 Transmission Provider’s Interconnection Facilities.....	38
Table 19 – GI-2021-9 Transmission Provider’s Interconnection Facilities.....	39
Table 20 – Total Cost of Station Network Upgrades by POI.....	40
Table 21 – Station Network Upgrades – Comanche 230 kV Substation.....	40
Table 22 – Station Network Upgrades – GI-2021-4 69 kV Switching Station.....	41
Table 23 – Station Network Upgrades – GI-2021-6 230 kV Switching Station.....	42
Table 24 – Station Network Upgrades – Tundra 345 kV Substation.....	43

## 1.0 Summary

The Phase 2 of the 3DISIS-2021-001 Definitive Interconnection System Impact Study (DISIS) Cluster includes six (6) Generator Interconnection Requests (GIR): GI-2021-1, GI-2021-2, GI-2021-3, GI-2021-4, GI-2021-6, and GI-2021-9. This revision of the Phase 2 Study Report reflects the withdrawal of GI-2021-8 from the 3DISIS-2021-001 Cluster.

**GI-2021-1** is a 200 MW<sub>ac</sub> net rated Solar Photovoltaic (PV) Generating Facility requesting Energy Resource Interconnection Service (ERIS). The requested Point of Interconnection (POI) is the Comanche 230 kV Substation.

**GI-2021-2** is an incremental increase to the existing Ft. St. Vrain #2 natural gas fired combustion turbine capacity. The requested increase is ERIS of 38 MW (summer) / 49 MW (winter).

**GI-2021-3** is an incremental increase to the existing Ft. St. Vrain #3 natural gas fired combustion turbine capacity. The requested increase is ERIS of 24 MW (summer) / 35 MW (winter).

**GI-2021-4** is a 42 MW<sub>ac</sub> net rated Solar PV plus Battery Energy Storage System (BESS) hybrid Generating Facility requesting Network Resource Interconnection Service (NRIS). The requested POI is a tap on the Romeo – Old40Tap 69 kV line.

**GI-2021-6** is a 199 MW<sub>ac</sub> net rated Solar PV plus BESS hybrid Generating Facility requesting NRIS. The requested POI is a tap on the Green Valley – Sky Ranch 230 kV line.

**GI-2021-9** is a 199 MW<sub>ac</sub> net rated Solar PV Generating Facility requesting ERIS. The requested POI is the Tundra 345 kV Switching Station.

GI-2021-1 and GI-2021-9 were studied under the Southern Colorado study pocket. GI-2021-4 was studied under the San Luis Valley study pocket. GI-2021-2, GI-2021-3, and GI-2021-6 were studied under the Northern Colorado study pocket.

The Interconnection Service determined for GIRs in this report in and of itself does not convey any transmission service.

### 1.1 GI-2021-1 Results

The total cost of the upgrades required to interconnect GI-2021-1 at the Comanche 230 kV Substation for ERIS is \$2.767 million (Table 14 and Table 21).

Maximum allowed output of GI-2021-1 without requiring additional Network Upgrades is 0 MW.

ERIS of GI-2021-1 is 200 MW when using the existing firm or non-firm capacity of the Transmission System on an “as available” basis.

## **1.2 GI-2021-2 Results**

The total cost of the upgrades required to allow GI-2021-2 expansion at the Fort Saint Vrain #2 generator for ERIS is \$0.05 million (Table 15).

Maximum allowed output of GI-2021-2 without requiring additional Network Upgrades is 0 MW.

ERIS of GI-2021-2 is 49 MW when using the existing firm or non-firm capacity of the Transmission System on an “as available” basis.

## **1.3 GI-2021-3 Results**

The total cost of the upgrades required to allow GI-2021-3 expansion at the Fort Saint Vrain #3 generator for ERIS is \$0.05 million (Table 16).

Maximum allowed output of GI-2021-3 without requiring additional Network Upgrades is 0 MW.

ERIS of GI-2021-3 is 35 MW when using the existing firm or non-firm capacity of the Transmission System on an “as available” basis.

## **1.4 GI-2021-4 Results**

The total cost of the upgrades required to interconnect GI-2021-4 on the Romeo – Old40Tap 69kV line for NRIS is \$13.613 million (Table 17 and Table 22).

Network Resource Interconnection of GI-2021-4 is 42 MW.

The charging of BESS in this hybrid Generating Facility will occur using the PV Solar generation output – hence no grid charging was studied.

## **1.5 GI-2021-6 Results**

The total cost of the upgrades required to interconnect GI-2021-6 on the Green Valley – Sky Ranch 230 kV line for NRIS is \$21.451 million (Table 18 and Table 23).

Network Resource Interconnection of GI-2021-6 is 199 MW.

The construction of the GI-2021-6 230 kV switching station tapping the Green Valley – Sky Ranch 230 kV line will require a Certificate of Public Convenience and Necessity (CPCN) and, the



estimated time frame for regulatory activities and to site, design, procure and construct the switching station is approximately 36 months after authorization to proceed has been obtained.

The charging of BESS in this hybrid Generating Facility will occur using the PV Solar generation output – hence no grid charging was studied.

## **1.6 GI-2021-9 Results**

The total cost of the upgrades required to interconnect GI-2021-9 at the Tundra 345 kV Switching Station for ERIS is \$4.889 million (Table 19 and Table 24).

Maximum allowed output of GI-2021-9 without requiring additional Network Upgrades is 0 MW.

ERIS of GI-2021-9 is 199 MW when using the existing firm or non-firm capacity of the Transmission System on an “as available” basis.



## 2.0 Introduction

The 3DISIS-2021-001 Definitive Interconnection System Impact Study Cluster Phase 1 Report was completed on 8/30/2021 and an addendum to the report was published on 9/15/2021. Links to both the reports are below:

[https://www.rmao.com/public/wtpp/Final\\_Studies/3DISIS-2021-001%20Phase%201%20Study%20Report.pdf](https://www.rmao.com/public/wtpp/Final_Studies/3DISIS-2021-001%20Phase%201%20Study%20Report.pdf)

[https://www.rmao.com/public/wtpp/Final\\_Studies/3DISIS-2021-001%20Phase1%20Study%20Report%20Addendum\\_final.pdf](https://www.rmao.com/public/wtpp/Final_Studies/3DISIS-2021-001%20Phase1%20Study%20Report%20Addendum_final.pdf)

The Phase 2 of the 3DISIS-2021-001 Definitive Interconnection Study Cluster (“3DISIS-2021-001”) consists of six (6) GIRs<sup>1</sup>, shown in the summary Table 1 below. The total Interconnection Service requested is 724 MW.

Out of the six (6) GIRs; GI-2021-1, GI-2021-2, GI-2021-3, and GI-2021-9 requested Energy Resource Interconnection Service (ERIS)<sup>2</sup> and, GI-2021-4, and GI-2021-6 requested Network Resource Interconnection Service (NRIS)<sup>3</sup>.

---

<sup>1</sup> GI-2021-8 has withdrawn from the 3DISIS-2021-001 Definitive Interconnection Study Cluster and its impact is reflected in this report

<sup>2</sup> Energy Resource Interconnection Service shall mean an Interconnection Service that allows the Interconnection Customer to connect its Generating Facility to the Transmission Provider’s Transmission System to be eligible to deliver the Generating Facility’s electric output using the existing firm or non-firm capacity of the Transmission Provider’s Transmission System on an as available basis. Energy Resource Interconnection Service in and of itself does not convey transmission service

<sup>3</sup> Network Resource Interconnection Service shall mean an Interconnection Service that allows the Interconnection Customer to integrate its Large Generating Facility with the Transmission Provider’s Transmission system (1) in a manner comparable to that in which the Transmission Provider integrates its generating facilities to serve native load customers; or (2) in an RTO or ISO with market based congestion management, in the same manner as all other Network Resources. Network Resource Interconnection Service in and of itself does not convey transmission service.

**Table 1 – Summary of GIRs in the 3DISIS-2021-001**

<b>GI#</b>	<b>Resource Type</b>	<b>Interconnection Service</b>	<b>COD</b>	<b>POI</b>	<b>Location</b>	<b>Service Type</b>
GI-2021-1	PV Solar	200 MW	12/31/2022	Comanche 230 kV Substation	Pueblo County, CO	ERIS
GI-2021-2	Gas CT	38 MW (summer) / 49 MW (Winter)	4/1/2022	Fort Saint Vrain #2	Weld County, CO	ERIS
GI-2021-3	Gas CT	24 MW (summer) / 35 MW (winter)	11/1/2021	Fort Saint Vrain #3	Weld County, CO	ERIS
GI-2021-4	PV Solar +BESS	42 MW	5/15/2024	Romeo – Old40Tap 69 kV line	Conejos County, CO	NRIS
GI-2021-6	PV Solar +BESS	199 MW	12/31/2024	Green Valley - Sky Ranch 230 kV line	Adams County, CO	NRIS
GI-2021-9	PV Solar	199 MW	12/1/2024	Tundra 345 kV Switching Station	Pueblo County, CO	ERIS
<b>Total</b>		<b>724 MW</b>				<b>ERIS+NRIS</b>

The approximate geographical locations of the POIs within the Transmission System are shown in Figure 1 below.

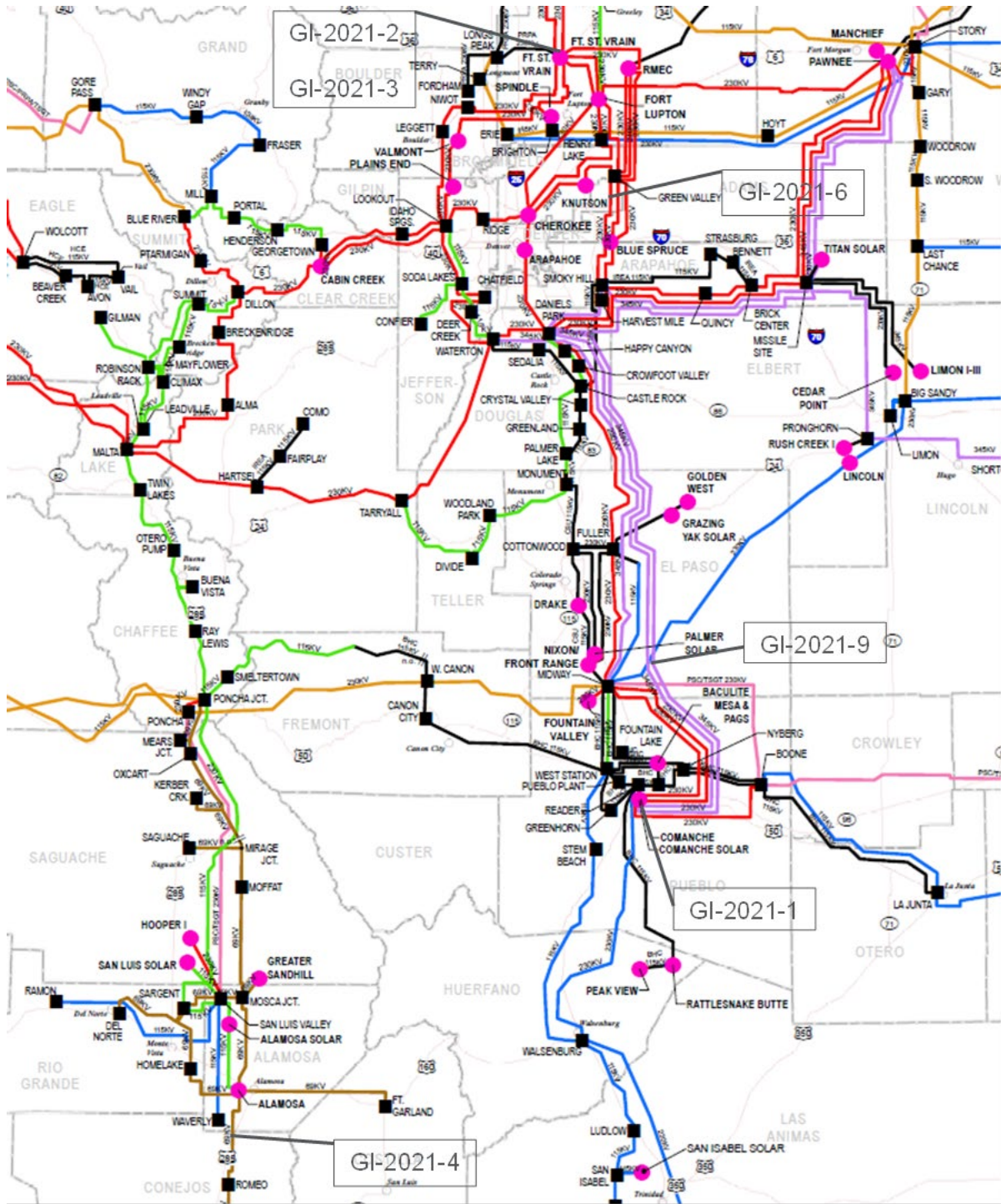

Figure 1 – Approximate Locations of 3DISIS-2021-001 Generator Interconnection Request POIs

### **3.0 Description of the GIRs**

#### **3.1 GI-2021-1**

GI-2020-1 is a 200 MW<sub>ac</sub> net rated Solar PV Generating Facility located in Pueblo County, Colorado. The Generating Facility configuration consists of two-hundred-sixty-five (265) TMEIC PV-L0880 inverters derated to 0.832 MVA at +/-0.92 pf. Each inverter will have its own 0.66/34.5 kV, 4 MVA Delta/Wye, Z=6.0% and X/R=8 pad-mount transformer. The 34.5 kV collector system will connect to one (1) 135/180/225 MVA, 230/34.5/13.8 kV Wye-grounded/Wye-grounded/Delta Z=8.5% and X/R=47.1 main step-up transformer which will connect to the PSCo transmission system via a 3.5-mile 230 kV generation tie-line. The POI is the Comanche 230 kV Substation.

The proposed Commercial Operation Date (COD) of GI-2021-1 is December 31, 2022. The back-feed date is assumed to be June 30, 2022, approximately six (6) months before the COD.

#### **3.2 GI-2021-2**

GI-2021-2 is a 38 MW (summer) / 49 MW (winter) incremental capacity in the output of the existing Fort Saint Vrain #2 Combustion Turbine generator located in Weld County, Colorado. The incremental output is driven by turbine prime mover changes being performed as part of maintenance and modernizing the equipment, and no changes to the electrical generator set are anticipated. The net generating capacity of Fort Saint Vrain #2 after GI-2021-2 addition will be 165 MW (summer) / 187 MW (winter).

The POI of the incremental capacity is the existing Fort Saint Vrain 230 kV Substation where Fort Saint Vrain #2 currently interconnects.

The COD is April 1, 2022 and the GIR is also studied under Provisional Interconnection Request PI-2021-2.

#### **3.3 GI-2021-3**

GI-2021-3 is a 34 MW (summer) / 35 MW (winter) incremental capacity in the output of the existing Fort Saint Vrain #3 Combustion Turbine generator located in Weld County, Colorado. The incremental output is driven by turbine prime mover changes being performed as part of maintenance and modernizing the equipment and no changes to the electrical generator set are anticipated. The net generating capacity of Fort Saint Vrain #3 after GI-2021-3 addition will be 156 MW (summer) / 178 MW (winter).

The POI of the incremental capacity is the existing Fort Saint Vrain 230 kV Substation where Fort Saint Vrain #3 currently interconnects.

The COD is November 1, 2021 and the GIR is also studied under Provisional Interconnection Request PI-2021-3.

### **3.4 GI-2021-4**

GI-2021-4 is a 42 MW<sub>ac</sub> net rated AC-coupled Hybrid Generating Facility located in Conejos County, Colorado. The Hybrid Generating Facility is composed of a 42 MW<sub>ac</sub> Solar PV Generating Facility and a 10.5 MW<sub>ac</sub> BESS Generating Facility, with the net output at the POI limited to 42 MW. The Solar Generating Facility will consist of thirteen (13) Power Electronics FS3510M PV inverters and the BESS Generating Facility will consist of three (3) Power Electronics FP3510M storage inverters, each with its own 0.66/34.5 kV, 3.51 MVA Delta/Wye Z=5.75%, X/R=8 pad-mount transformer. The 34.5 kV collector system of the PV and BESS resources will connect to one (1) 69/34.5 kV, 27.52/36.39/45.63 MVA Wye-grounded/Delta Z=8% and X/R=53 main step-up transformer which will interface with a 69 kV, 242-foot generation tie-line. The POI is a tap on PSCo's Romeo – Old40Tap 69 kV line, at approximately 1.63 miles from the Romeo Substation. The tap point at the POI will require a new switching station which is referred to as “GI-2021-4 69 kV Switching Station” in this report.

The BESS facility has a maximum state of charge of 10.5 MW and minimum state of charge of 0 MW.

Per the Interconnection Request, the NRIS output of GI-2021-4 will be serving PSCo native load.

The proposed COD of GI-2021-4 is May 15, 2024. For the study purposes, the back-feed date is assumed to be November 15, 2023, approximately six (6) months before the COD.

### **3.5 GI-2021-6**

GI-2021-6 is a 199 MW<sub>ac</sub> net rated AC-coupled Hybrid Generating Facility located in Adams County, Colorado. The Hybrid facility is composed of a 207.8 MW<sub>ac</sub> Solar PV Generating Facility and a 100 MW<sub>ac</sub>, 4-hour BESS Generating Facility, with the net output at the POI limited to 199 MW. The solar PV Generation Facility will consist of fifty-four (54) Power Electronics FS4200M inverters and the BESS Generating Facility will consist of twenty-eight (28) Power Electronics FP4200M inverters; each inverter will utilize the built-in 0.60/34.5 kV, 4.20 MVA Wye/Delta Z=6.5%, X/R=8 pad-mount transformer to interface with the 34.5 kV collector system. The 34.5

kV collector system of the PV and BESS units will connect to one (1) 150/188/250 MVA, 34.5/230 kV Wye-grounded/Wye-grounded/Delta,  $Z=9.5\%$ ,  $X/R=70$  main step-up transformer, which will connect to PSCo's Green Valley—Sky Ranch 230 kV line, at approximately 2.16 miles from the Sky Ranch Substation. The tap point at the POI will require a new switching station which is referred to as "GI-2021-6 230 kV Switching Station" in this report. The Generating Facility configuration also includes a 31 Mvar capacitor bank installed on the 34.5 kV collector system.

Per the Interconnection Request, the NRIS output of GI-2021-4 will be serving PSCo native load.

The BESS facility has a maximum state of charge of 100% and minimum state of charge of 4%.

The proposed COD of GI-2021-6 is December 31, 2024. For the study purpose, the back-feed date is assumed to be July 1, 2024, approximately six (6) months before the COD.

### **3.6 GI-2021-9**

GI-2021-9 is a 199 MW<sub>ac</sub> net rated solar PV Generating Facility located in Pueblo County, Colorado. The Generation Facility will consist of sixty-eight (68) Power Electronics FS3350M inverters rated at 3.02 MW, each with its own 0.66/34.5 kV, 3.63 MVA Delta/Wye  $Z=8.5\%$ ,  $X/R=10.5$  pad-mount transformer. The 34.5 kV collector system will connect to one (1) 345/34.5/13.8 kV, 135/180/225 MVA Wye-grounded/Wye-grounded/Delta  $Z=8.5\%$ ,  $X/R=35$  main step-up transformer which will connect to the PSCo transmission system via a 0.5-mile 345 kV generation tie-line. The POI is the Tundra 345 kV Switching Station (POI identified for GI-2018-24).

The proposed COD of GI-2021-9 is December 1, 2024. For the study purpose, the back-feed date is assumed to be June 1, 2024, approximately six (6) months before the COD.

## 4.0 Study Scope

Phase 2 of the Definitive Interconnection System Impact Study (DISIS) scope consists of:

- a. An updated power flow/voltage analysis (if necessary),
- b. Stability analysis and short-circuit analysis,
- c. Non-binding cost estimates for the Transmission Provider's Interconnection Facilities, Station Network Upgrades and System Network Upgrades required to reliably interconnect the GIR(s),
- d. Each Interconnection Customer's assigned costs based on the total non-binding cost estimates determined above, and
- e. Identification of Contingent Facilities applicable to each GIR.

Since the completion of the Phase 1 study report on 8/30/2021, the following two changes made it necessary to update the relevant power flow analyses in the Phase 2 study.

1. Correction of Tri-State's Vollmert to Black Squirrel 115 kV line rating.
2. Incremental capacity increase of existing generating units is studied by dispatching other generating units with common fuel type within the same generating facility at 100% rated output.

## 4.1 Study Pockets

As shown in Figure 1,

- GI-2021-1 and GI-2021-9 are in the Southern Colorado study pocket.
- GI-2021-2, GI-2021-3 and GI-2021-6 are in the Northern Colorado study pocket.
- GI-2021-4 is in the San Luis Valley study pocket.

Each study pocket analysis only modeled the GIRs with POI in that study pocket.

## 4.2 Study Areas

The study area for the Southern Colorado study pocket includes the WECC base case zones 704, 710, 712, 751, 757, and 785. The Affected Systems included in the analysis include Tri-State Generation and Transmission Inc. (TSGT), Black Hills Energy (BHE), Colorado Spring Utilities (CSU), Intermountain Rural Electric Association (IREA) and Western Area Power Administration (WAPA) transmission systems in the study area.

The study area for the Northern Colorado study pocket includes the WECC base case zones 700, 703 and 706. The Affected Systems included in the analysis include TSGT transmission systems in the study area.

The study area for the San Luis Valley study pocket includes the WECC base case zone 710. The Affected Systems included in the analysis include TSGT and WAPA transmission systems in the study area.

### **4.3 Study Criteria**

The following criteria is used for the reliability analysis of the PSCo system and Affected Systems. The transient voltage stability criteria are as follows:

- a. Following fault clearing, voltage shall recover to 80% of the pre-contingency voltage within 20 seconds of the initiating event for all P1 through P7 events for each applicable Bulk Electric System (BES) bus serving load.
- b. Following fault clearing and voltage recovery above 80%, voltage at each applicable BES bus serving load shall neither dip below 70% of pre-contingency voltage for more than 30 cycles nor remain below 80% of pre-contingency voltage for more than two seconds, for all P1 through P7 events.
- c. For contingencies without a fault (P2.1 category event), voltage dips at each applicable BES bus serving load shall neither dip below 70% of pre-contingency voltage for more than 30 cycles nor remain below 80% of pre-contingency voltage for more than two seconds.
- d. Please note, generator bus frequency plots are included, however, PSCo does not have criteria for frequency events.

The transient angular stability criteria are as follows:

- a. P1 – No generating unit shall pull out of synchronism. A generator being disconnected from the system by fault clearing action or by a special Protection System is not considered an angular instability.
- b. P2-P7 – One or more generators may pull out of synchronism, provided the resulting apparent impedance swings shall not result in the tripping of any other generation facilities.
- c. P1-P7 – The relative rotor angle (power) oscillations are characterized by positive damping (i.e., amplitude reduction of successive peaks) > 5% within 30 seconds.



The breaker duty analysis criterion is fault current after GIR(s) addition should not exceed 100% of the breaker duty rating.

## **4.4 Study Methodology**

### **4.4.1 Transient Stability Study Methodology**

All generators in the study pocket should meet the transient stability criteria. If any violations are found, the contributing GIR(s) will be identified for performance violations and mitigations will be attributed to the contributing generator(s). The stability analysis is performed by running select single and multiple contingencies in the study pocket.

### **4.4.2 Short-Circuit and Breaker-Duty Study Methodology**

The study was performed using the short-circuit model maintained for the PSCo owned system. This model includes only a small portion of Affected System(s) at the seams, and breaker duty on Affected System(s) was not evaluated in this study. The Affected Systems may choose to perform their own study to identify potential for breaker duty violations on their system.

A Benchmark Case aligned with the Phase 1 Base Case was developed using Siemens PSS@CAPE short-circuit analysis software (CAPE) which included both higher-queued ERIS and NRIS GIRs modeled at full output. The Study Case in CAPE was created from the Benchmark Case by modeling all NRIS and ERIS GIRs in the 3DISIS-2021-001 Cluster, and their associated Network Upgrades identified in the Phase 1 report. Facility rating upgrades to existing lines were neglected for short-circuit studies.

GIRs are modeled on a per-machine basis, using the impedance and configuration information provided in the Interconnection Request. If tie-line length was not specified, gen-tie lines were assumed to have a length of 0.25 miles, with estimated impedance appropriate for the voltage. All inverter-based generation, including generator step-up transformers, were modeled on an aggregate basis using appropriately scaled generic models at the low side of the main power transformer(s).

All generating facilities, regardless of NRIS or ERIS, were modeled on-line at rated capacity and assumed capable of producing maximum fault current. Hybrid generating facilities (e.g. solar with battery storage) were modeled with each technology modeled as a separate generating resource at its rated capacity, regardless of any limitations to the combined output that would be imposed otherwise.

Short-circuit current and equivalent system impedances were obtained for both the Benchmark Case and the Study Case from CAPE for three-phase and single-line-to-ground faults at each POI for GIRs in the 3DISIS-2021-001 Cluster.

Breaker duty studies are performed for the Benchmark Case for the entire system. Circuit breakers identified as overstressed (0% margin) in the Benchmark Case study are not included in the analysis. However, these are identified as Contingent Facilities to the 3DISIS-2021-001 GIRs if there is an increase in fault current contribution to these breakers from the Study Case evaluation.

Breaker duty studies are conducted using a sub-transient fault analysis. Single and three-phase faults are placed at each substation in the system. Each breaker is modeled by the manufacturer and model number with the catalog characteristics for that breaker and its application, i.e., the relevant standard applying to that breaker's date of manufacture, kA interrupting rating, voltage rating, relay operate time, breaker interrupting time, proximity to generation, etc. The reclosing scheme is not considered in the analysis. The aforementioned factors are used to calculate an XR factor according to ANSI C37.010-1999, ANSI C37.5-1979, or C37.6-1971. For evaluation of breaker opening by C37.010-1999, applicable to all breakers identified in this study, and with no reclosing and no additional derating, the equivalent current that the breaker is required to interrupt is simply the fault current multiplied by the XR factor ( $I_{\text{breaking}}$ ). This is compared against that breaker's rated interrupting capacity to determine whether the breaker is overstressed. If it is greater than the breaker's interrupting capacity, it is considered to be overstressed (0% margin).

Breaker duty studies are re-performed while excluding each individual interconnection and corresponding network upgrade, one at a time. Fault currents at the location of each identified overdutied breaker are compared to determine the relative contribution of each interconnection and corresponding network upgrade.

Then, cost allocation is determined as follows:

$$Allocation\% = \frac{Fault\ Current\ Reduction\ due\ to\ Removal\ of\ GI\ of\ interest}{\sum\ Fault\ Current\ Reduction,\ All\ GIs} * 100$$

Where

$$Fault\ Current\ Reduction = (Fault\ Current\ at\ Breaker,\ All\ GIs\ connected) - (Fault\ Current\ at\ Breaker,\ All\ GIs\ connected\ except\ GI\ of\ interest)$$

And,

*the Fault Type matches the fault type (3-phase or phase-to-ground) causing the breaker to be overstressed.*

**Figure 2 – Cost Allocation Calculation**

## 4.5 Study Analyses

The Phase 1 steady-state power flow and voltage analysis results for San Luis Valley study pocket was not impacted by the Vollmert to Black Squirrel 115 kV line rating correction or by the updated generation dispatch approach for studying incremental capacity increases of existing generating units, which dispatches other generating units with common fuel type within the same generating facility at 100% rated output. Therefore, this Phase 2 study needed an updated steady-state analyses for only the Southern Colorado and Northern Colorado (ERIS) study pockets.

Steady-state power flow analyses were performed using PowerGEM TARA software. The generation redispatch for ERIS is identified using TARA.

Short circuit analyses in Phase 2 studies were performed using Siemens PSS®CAPE short-circuit analysis software (CAPE). Facility rating upgrades to existing lines were neglected for short-circuit analyses. Short circuit current and equivalent system impedances were obtained for both the Benchmark Case and the Study Case from CAPE for three-phase and single-line-to-ground faults at each POI for GIRs in the 3DISIS-2021-001 Cluster.

Note that GI-2021-2 and GI-2021-3 are incremental capacity increases in the output of the existing generator with no proposed changes to the electrical characteristics of the generator, so the fault current contribution would remain unchanged.

No overstressed breakers attributable to GI-2021-1, GI-2021-6, or GI-2021-9 fault current contributions were identified by the breaker duty study.

Transient stability analyses in Phase 2 studies were performed using a transient stability Study Case developed in GE PSLF corresponding to the Phase 1 PSS/E Study Case.

Select P1, P4 and P7 disturbance events were simulated in Phase 2 stability analyses. The P1 disturbance events are simulated using three-phase bolted fault, and the P4 and P7 disturbance events are simulated using single-phase line to ground (SLG) fault through a fault impedance resulting in faulted bus residual voltage of approximately 60-70% of nominal voltage.

## **4.6 Southern Colorado Study Pocket Analysis**

The Study Case modeled GI-2021-1 connecting to Comanche 230 kV Substation and GI-2021-9 connecting to the Tundra 345 kV station. The Phase 1 study report did not identify any Network Upgrades that would have to be modeled in the Phase 2 report.

### **4.6.1 Steady-State Analysis**

The Benchmark Case and Study Case created for the Phase 1 study were updated to implement the rating correction of the Vollmert to Black Squirrel 115 kV line from 173 MVA to 143 MVA. As stated in the Phase 1 report, the multiple contingency analysis is done for informational purposes only and overloads are mitigated using system adjustments, including generation redispatch and/or operator actions. The Phase 2 restudy of the power flow analysis included only single contingency analysis.

#### **ERIS Steady State Analysis:**

There were no NRIS GIRs in the Southern Colorado Study Pocket. Therefore, the ERIS Study Case was developed from Benchmark Case by making the following modifications:

- GI-2021-1 is modeled at Comanche 230 kV and dispatched at 100%
- GI-2021-9 is modeled at Tundra 345 kV and dispatched at 100%
- The ERIS output of GI-2021-1 and GI-2021-9 was balanced by reducing all PSCo and non-PSCo generation outside the study pocket on a pro-rata basis

The results of the single contingency analysis for the ERIS Study Case are given in Table 2, below.

Table 2 – Southern Colorado Study Pocket ERIS Study Overloads Identified in Single Contingency Analysis

Overloaded Facility	Type	Area	Facility Normal Rating (MVA)	Facility Loading in ERIS Benchmark Case		Facility Loading in ERIS Study Case		Loading % Change Due to Study Pocket GIRs	Single Contingency Definition	DFAX - Contingency	
				MVA Flow	% Loading	MVA Flow	% Loading			GI-2021-1	GI-2021-9
72413 VOLLMERT 115 kV TO FULLER FULLER 115 kV CKT 1	Line	73	143	185.2	129.51	203.3	142.18	12.67	70139 DANIELSPK 230 kV TO 78854 FULLER 230 kV CKT 1	0.0415	0.0336
70463 WATERTON 115 kV TO WATERTN_TP WATERTN_TP 115 kV CKT 1	Line	70	127	166.8	131.34	176.7	139.15	7.81	70100 CHATFLD 230 kV TO 70464 WATERTON 230 kV CKT 1	0.0369	0.0365
72413 VOLLMERT 115 kV TO BLK SQMV BLK SQMV 115 kV CKT 1	Line	73	143	180.3	126.11	198.4	138.73	12.62	70139 DANIELSPK 230 kV TO 78854 FULLER 230 kV CKT 1	0.0415	0.0336
70139 DANIELPK 230 kV TO FULLER FULLER 230 kV CKT 1	Line	70	478	508	106.27	592.9	124.04	17.77	70601 DANIELPK 345 kV TO 70653 TUNDRA 345 kV CKT 2	0.1649	0.154
70550 W.CANON 115 kV TO HOGBACK115 HOGBACK115 115 kV CKT 1	Line	70	120	134.7	112.23	148	123.31	11.08	73413 MIDWAYBR 230 kV TO 73551 W CANON 230 kV CKT 1	0.089	0.0817
70286 MIDWAYPS 230 kV TO MIRASOL MIRASOL 230 kV CKT 1	Line	70	478	468.4	98	565.9	118.39	20.39	70654 COMANCHE 345 kV TO 704561 GI-20-14_SUB 345 kV CKT 1	0.2304	0.2235
70212 GREENWD 230 kV TO PRAIRIE3 PRAIRIE3 230 kV CKT 1	Line	70	576	615.9	106.93	665.1	115.47	8.54	70139 DANIELPK 230 kV TO 70331 PRAIRIE1 230 kV CKT 1	0.1406	0.1412

Overloaded Facility	Type	Area	Facility Normal Rating (MVA)	Facility Loading in ERIIS Benchmark Case		Facility Loading in ERIIS Study Case		Loading % Change Due to Study Pocket GIRs	Single Contingency Definition	DFAX - Contingency	
				MVA Flow	% Loading	MVA Flow	% Loading			GI-2021-1	GI-2021-9
70212 GREENWD 230 kV TO PRAIRIE1 PRAIRIE1 230 kV CKT 2	Line	70	576	598.3	103.88	647.8	112.46	8.58	70139 DANIELPK 230 kV TO 70323 PRAIRIE3 230 kV CKT 2	0.1406	0.1412
70654 COMANCHE 345 kV TO GI-20-14_SUB GI-20-14_SUB 345 kV CKT 1	Line	70	1195	1094.3	91.57	1299.4	108.74	17.17	70601 DANIELPK 345 kV TO 70653 TUNDRA 345 kV CKT 2	0.4191	0.4725
70464 WATERTON 230 kV TO WATRTN - WATRTN - 230 kV CKT T3	Line	70	560	529.4	94.53	593.1	105.91	11.38	70466 WATERTON 345 kV TO 3WXFMR WATRTN - _1 kV CKT T4	0.1733	0.164
70466 WATERTON 345 kV TO WATRTN - WATRTN - 230 kV XFMR T3	Xfmr	70	560	525.1	93.77	586	104.64	10.87	70466 WATERTON 345 kV TO 3WXFMR WATRTN - _1 kV XFMR T4	0.1733	0.164
70308 PALMER 115 kV TO MONUMENT MONUMENT 115 kV CKT 1	Line	70/73	151	135.7	89.85	157.6	104.4	14.55	70139 DANIELSPK 230 kV TO 78854 FULLER 230 kV CKT 1	0.0418	0.0319
78657 BRIARGATE S 115 kV TO CTTNWD S CTTNWD S 115 kV CKT 1	Line	70	150	144.6	96.43	154.2	102.77	6.34	78658 CTTNWD N 115 kV TO 78673 KETTLECK S 115 kV CKT 1	0.021	0.0169
70449 DESRTOV 115 kV TO W.STATON W.STATON 115 kV CKT 1	Line	70	222	196.9	88.69	227.9	102.68	13.99	70654 COMANCHE 345 kV TO 704561 GI-20-14_SUB 345 kV CKT 1	0.0767	0.0541

Overloaded Facility	Type	Area	Facility Normal Rating (MVA)	Facility Loading in ERIS Benchmark Case		Facility Loading in ERIS Study Case		Loading % Change Due to Study Pocket GIRs	Single Contingency Definition	DFAX - Contingency	
				MVA Flow	% Loading	MVA Flow	% Loading			GI-2021-1	GI-2021-9
73414 MONUMENT 115 kV TO GRESHAM GRESHAM 115 kV CKT 1	Line	73	145	130.7	90.12	148.3	102.27	12.15	70139 DANIELSPK 230 kV TO 78854 FULLER 230 kV CKT 1	0.0415	0.0336
70550 W.CANON 115 kV TO W CANON W CANON 230 kV XFMR T1	Xfmr	70/73	100	88.3	88.3	101.3	101.26	12.96	73413 MIDWAYBR 230 kV TO 73551 W CANON 230 kV CKT 1	0.0921	0.0846
70142 DEERCRK 115 kV TO SODALAKE SODALAKE 115 kV CKT 1	Line	70	120	111.1	92.62	121.5	101.25	8.63	70100 CHATFLD 230 kV TO 70464 WATERTON 230 kV CKT 1	0.0369	0.0365
78854 FULLER 230 kV TO FULLER FULLER 115 kV XFMR 2	Xfmr	70/73	100	95.8	95.81	100.3	100.27	4.46	73412 MIDWAYBR 115 kV TO 73416 RANCHO 115 kV CKT 1	0.0124	0.0104
78854 FULLER 230 kV TO FULLER FULLER 115 kV XFMR 1	Xfmr	70/73	100	95.8	95.81	100.3	100.27	4.46	73412 MIDWAYBR 115 kV TO 73416 RANCHO 115 kV CKT 1	0.0124	0.0104
73412 MIDWAYBR 115 kV TO RANCHO RANCHO 115 kV CKT 1	Line	73	119	107.4	90.28	119.2	100.18	9.9	70601 DANIELPK 345 kV TO 70653 TUNDRA 345 kV CKT 2	0.0246	0.0214

For all the overloads shown in Table 2, a redispatch based on Optimal Power Flow (OPF) mitigated the overloads.

The maximum output of the ERIS GIRs without requiring additional Network Upgrades are:

- ERIS of GI-2021-1 is 0 MW
- ERIS of GI-2021-9 is 0 MW

The Phase 1 report did not identify any impacts to Affected Systems.

### 4.6.2 Transient Stability Analysis

Table 3 is a summary of the contingencies studied and the corresponding stability results. The following results were obtained for the disturbances analysis:

- ✓ No machines lost synchronism with the system
- ✓ No transient voltage drop violations were observed
- ✓ Machine rotor angles displayed positive damping

The transient stability analysis was performed using the generation redispatch scenario determined by OPF in the Phase 1 study to resolve new overloads caused by GI-2021-1 and GI-2021-9 projects. The stability issues observed using the standard generation dispatch did not occur for the OPF redispatch scenario.

The transient stability plots are shown in Section 9.0 in this report.

**Table 3 – Southern Colorado Transient Stability Analysis Results**

#	Fault Location	Fault Category	Fault Type	Facility Tripped	Clearing Time (cycles)	Post-Fault Voltage Recovery	Angular Stability
1	Comanche 345 kV	P1	3ph	Comanche Generator #3	4.0	Stable	Stable
2	Comanche 345 kV	P7	SLG	Comanche - GI-12-14 345 kV line and Comanche - Mirasol 345 kV line	4.0	Stable	Stable
3	Daniels Park 345 kV	P7	SLG	Daniels Park - GI-12-14 345 kV line and Daniels Park - Tundra 345 kV line	4.0	Stable	Stable



#	Fault Location	Fault Category	Fault Type	Facility Tripped	Clearing Time (cycles)	Post-Fault Voltage Recovery	Angular Stability
4	Tundra 345 kV	P7	SLG	Daniels Park - GI-12-14 345 kV line and Daniels Park - Tundra 345 kV line	4.0	Stable	Stable
5	Tundra 345 kV	P7	SLG	Comanche - GI-12-14 345 kV line and Tundra - Mirasol 345 kV line	4.0	Stable	Stable
6	GI-12-14 345 kV	P7	SLG	GI-12-14 - Waterton 345 kV line and GI-12-14 - Daniels Park 345 kV line	4.0	Stable	Stable
7	GI-12-14 345 kV	P7	SLG	GI-12-14 - Midway 345 kV line and GI-12-14 - Comanche 345 kV line	4.0	Stable	Stable
8	Comanche 230 kV	P7	SLG	Comanche - GI-2014-9 230 kV line, Comanche - Mirasol 230 kV line	5.0	Stable	Stable
9	Midway 230 kV	P4	SLG	Midway - Fuller 230 kV line, Midway BR 230 kV Station, and Midway BR 115 kV Station	22.0	Stable	Stable
10	Tundra 345 kV	P1	3ph	Tundra - CEP_6 345 kV Attachment Line, CEP_6 Generation	4.0	Stable	Stable
11	Daniels Park 345 kV	P1	3ph	Daniels Park - Tundra 345 kV line 2	4.0	Stable	Stable
12	Lamar 230 kV	P1	3ph	Lamar - Boone 230 kV line, Lamar DC Generation, Colorado Green E and W Generation	5.0	Stable	Stable

The study did not identify any impacts to Affected Systems.

### 4.6.3 Short-Circuit Analysis Results

Fault currents at the POI are as follows:

**Table 4 – Short-Circuit Parameters at GI-2021-1 POI**

	Before the Cluster addition	After the Cluster addition
<b>Three Phase</b>		
Three Phase Current	31124 A	31478 A
Positive Sequence Impedance	0.34651 + j5.22689 ohms	0.34651 + j5.22689 ohms
Negative Sequence Impedance	0.35943 + j5.25082 ohms	0.35943 + j5.25082 ohms
Zero Sequence Impedance	0.17837 + j2.47610 ohms	0.17569 + j2.18562 ohms
<b>Phase-to-Ground</b>		
Single Line to Ground Current	34848 A	36480 A
Positive Sequence Impedance	0.36758 + j4.82162 ohms	0.36758 + j4.82162 ohms
Negative Sequence Impedance	0.37887 + j4.84115 ohms	0.37887 + j4.84115 ohms
Zero Sequence Impedance	0.17837 + j 2.47610 ohms	0.17569 + j2.18562 ohms

**Table 5 – Short-Circuit Parameters at GI-2021-9 POI**

	Before the Cluster addition	After the Cluster addition
<b>Three Phase</b>		
Three Phase Current	13349 A	13470 A
Positive Sequence Impedance	2.03010 + j17.8977 ohms	2.03010 + j17.8977 ohms
Negative Sequence Impedance	2.05218 + j17.9303 ohms	2.05218 + j17.9303 ohms
Zero Sequence Impedance	2.93323 + j22.0334 ohms	1.85488 + j16.8476 ohms
<b>Phase-to-Ground</b>		
Single Line to Ground Current	11304 A	12925 A
Positive Sequence Impedance	1.70804 + j15.9041 ohms	1.70804 + j15.9041 ohms
Negative Sequence Impedance	1.72339 + j15.9275 ohms	1.72339 + j15.9275 ohms
Zero Sequence Impedance	2.93323 + j22.0334 ohms	1.85488 + j16.8476 ohms

#### **4.6.4 Summary of Southern Colorado Study Pocket Analysis**

The Phase 1 and Phase 2 studies did not identify any network upgrades.

The maximum allowed output of the ERIS GIRs without requiring additional Network Upgrades is:

- GI-2021-1: 0 MW
- GI-2021-9: 0 MW

Energy Resource Interconnection Service, when using the existing firm or non-firm capacity of the Transmission System on an “as available” basis is:

- GI-2021-1: 200 MW
- GI-2021-9: 199 MW

The studies did not identify any impacts to the Affected Systems.

## 4.7 San Luis Valley Study Pocket Analysis

The Study Case modeled GI-2021-4 tapping the Romeo – Old40Tap 69 kV line. The Phase 1 study report did not identify any Network Upgrades that would have to be modeled in the Phase 2 report.

### 4.7.1 Steady-State Analysis

The Phase 1 study did not identify any Network Upgrades attributable to GI-2021-4.

The Phase 1 report did not identify any impacts to the Affected Systems.

### 4.7.2 Transient Stability Analysis

The results of the transient stability analysis are shown in Table 6. The following results were obtained for the disturbances analysis:

- ✓ No machines lost synchronism with the system
- ✓ No transient voltage drop violations were observed
- ✓ Machine rotor angles displayed positive damping

The transient stability plots are shown in Section 9.0 in this report.

**Table 6 – Heavy Summer and Light Load San Luis Valley Transient Stability Analysis Results**

#	Fault Location	Fault Category	Fault Type	Facility Tripped	Clearing Time (cycles)	Post-Fault Voltage Recovery	Angular Stability
1	San Luis Valley 230 kV	P1	3ph	San Luis Valley - Poncha 230 kV line	5.0	Stable	Stable
2	San Luis Valley 230 kV	P2	3ph	San Luis Valley - Poncha 230 kV line, SunPower PV, SLV SVD, 2x 230/115 kV SLV Transformers	5.0	Stable	Stable
3	San Luis Valley 115 kV	P4	SLG	San Luis Valley - Sargent 115 kV line, San Luis Valley - Stanley 115 kV line, San Luis Valley - Waverly 115 kV line, San Luis Valley - Blanca Peak 115 kV line, Hooper PV, 2x 230/115 kV SLV Xfmrs, 2x 115/69 kV Xfmrs	22.0	Stable	Stable
4	Romeo 69 kV	P1	3ph	Romeo - Antonito 69 kV line, Romeo - Alamosa Terminal 69 kV line, Alamosa Terminal - Alamosa Switchyard 69 kV line, Alamosa Switchyard - Ft. Garland 69 kV line, GI-2021-4 Generation	6.0	Stable	Stable

#	Fault Location	Fault Category	Fault Type	Facility Tripped	Clearing Time (cycles)	Post-Fault Voltage Recovery	Angular Stability
5	Alamosa Switchyard 69 kV	P1	3ph	Alamosa Switchyard - Mosca Jct. 69 kV line, Alamosa Switchyard - Old 16 Tap 69 kV line, Alamosa Switchyard - Alamosa Terminal 69 kV line, Alamosa Switchyard Load	6.0	Stable	Stable

### 4.7.3 Short-Circuit Analysis Results

Fault currents at the POI are as follows:

Table 7 – Short-Circuit Parameters at GI-2021-4 POI

	Before the Cluster addition	After the Cluster addition
<b>Three Phase</b>		
Three Phase Current	1176 A	1176 A
Positive Sequence Impedance	18.6235 + j28.2935 ohms	18.6216 + j28.2912 ohms
Negative Sequence Impedance	18.6686 + j28.2536 ohms	18.6667 + j28.2512 ohms
Zero Sequence Impedance	16.4377 + j50.0485 ohms	16.4374 + j50.0461 ohms
<b>Phase-to-Ground</b>		
Single Line to Ground Current	1001 A	1301 A
Positive Sequence Impedance	18.6235 + j28.2935 ohms	18.6216 + j28.2912 ohms
Negative Sequence Impedance	18.6686 + j28.2536 ohms	18.6667 + j28.2512 ohms
Zero Sequence Impedance	16.4377 + j50.0485 ohms	16.4374 + j50.0461 ohms

### 4.7.4 Summary of San Luis Valley Study Pocket Analysis

The transient stability analysis did not identify any Network Upgrades. The Phase 1 study did not identify any network upgrades:

Based on the analysis performed in the Phase 1 and Phase 2 studies, the results of the GI-2021-4 are as follows:

- NRIS identified for GI-2021-4 is 42 MW

The studies did not identify any impacts to the Affected Systems.

## 4.8 Northern Colorado Study Pocket Analysis

The GI-2021-6 is modeled by tapping the Green Valley – Sky Ranch 230 kV line. The GI-2021-2 is modeled as an incremental capacity increase to Fort Saint Vrain #2. The GI-2021-3 is modeled as an incremental capacity increase to Fort Saint Vrain #3. The mwcap parameter in the GGOV1 model for Fort Saint Vrain #2 was increased from 133.3 to 192. The mwcap parameter in the GGOV1 model for Fort Saint Vrain #3 was increased from 160 to 183. The increases in mwcap were made to accommodate the gross output necessary to meet the net generating capacity requested.

### 4.8.1 Steady-State Analysis

The Benchmark Case and Study Case created for the Phase 1 study was updated to include a dispatch assumption change for the Fort Saint Vrain plant. Incremental capacity increases of existing generating units are studied by dispatching other generating units with common fuel types within the same generating facility at 100% rated output. As stated in the Phase 1 report, the multiple contingency analysis is done for informational purposes only and overloads are mitigated using system adjustments, including generation redispatch and/or operator actions. The restudy of the power flow analysis only included single contingency analysis.

#### **ERIS Steady State Analysis:**

Following the evaluation of the GI-2021-6 NRIS GIR, the ERIS Study Case was developed from NRIS Study Case by making the following modifications:

- GI-2021-2 is modeled as an incremental increase to Fort Saint Vrain #2.
- GI-2021-3 is modeled as an incremental increase to Fort Saint Vrain #3.
- The ERIS output of GI-2021-2 and GI-2021-3 was balanced by reducing all PSCo and non-PSCo generation outside the study pocket on a pro-rata basis.

The results of the single contingency analysis for the updated ERIS Study Case are given in Table 8 below.

**Table 8 – Northern Colorado Study Pocket ERIS Study Overloads Identified in Single Contingency Analysis**

Overloaded Facility	Type	Area	Facility Normal Rating (MVA)	Facility Loading in ERIS Benchmark Case		Facility Loading in ERIS Study Case		Loading % Change Due to Study Pocket GIRs	Single Contingency Definition	DFAX Contingency	
				MVA Flow	% Loading	MVA Flow	% Loading			GI-2021-2	GI-2021-3
70444 VALMONT 115 kV TO 70447 VALMONT 230 kV XFMR T7	Xfmr	70	280	280.42	100.15	283.2	101.16	2.3	70444 VALMONT 115 kV TO 70447 VALMONT 230 kV XFMR T8	0.0186	0.0186
70444 VALMONT 115 kV TO 70447 VALMONT 230 kV XFMR T8	Xfmr	70	280	280.42	100.15	283.2	101.16	2.3	70444 VALMONT 115 kV TO 70447 VALMONT 230 kV XFMR T7	0.0186	0.0186

The maximum output of the ERIS GIRs without requiring additional Network Upgrades is:

- ERIS of GI-2021-2 is 0 MW
- ERIS of GI-2021-3 is 0 MW

The Phase 1 report did not identify any impacts to the Affected Systems.

Energy Resource Interconnection Service, when using the existing firm or non-firm capacity of the Transmission System on an “as available” basis is:

- GI-2021-2: 49 MW
- GI-2021-3: 35 MW

## 4.8.2 Transient Stability Results

The results of the transient stability analysis are shown in Table 9. The following results were obtained for the disturbances analysis:

- ✓ No machines lost synchronism with the system
- ✓ No transient voltage drop violations were observed
- ✓ Machine rotor angles displayed positive damping

The transient stability plots are shown in Section 9.0 in this report.

**Table 9 – Northern Colorado Transient Stability Analysis Results**

#	Fault Location	Fault Category	Fault Type	Facility Tripped	Clearing Time (cycles)	Post-Fault Voltage Recovery	Angular Stability
1	GI-2021-6 POI 230 kV	P1	3ph	GI-2021-6 POI - Green Valley 230 kV line	5.0	Stable	Stable
2	GI-2021-6 POI 230 kV	P1	3ph	GI-2021-6 POI - Sky Ranch 230 kV line	5.0	Stable	Stable
3	Green Valley 230 kV	P4	SLG	Green Valley - Ft. Lupton 230 kV line, Green Valley - Barr Lake 230 kV line	22.0	Stable	Stable
4	RMEC 230 kV	P1	3ph	RMEC G1, G2, and ST	5.0	Stable	Stable
5	RMEC 230 kV	P1	3ph	RMEC G1, and Half of ST	5.0	Stable	Stable
6	Fort Saint Vrain 230 kV	P1	3ph	Fort Saint Vrain – Fort Lupton 230 kV line 1	5.0	Stable	Stable
7	Fort Saint Vrain 230 kV	P1	3ph	Fort Saint Vrain – Fort Lupton 230 kV line 2	5.0	Stable	Stable



#	Fault Location	Fault Category	Fault Type	Facility Tripped	Clearing Time (cycles)	Post-Fault Voltage Recovery	Angular Stability
8	Fort Saint Vrain 230 kV	P1	3ph	Fort Saint Vrain – Weld PS 230 kV line 1	5.0	Stable	Stable
9	Fort Saint Vrain 230 kV	P1	3ph	Fort Saint Vrain – Windsor 230 kV line 1	5.0	Stable	Stable
10	Fort Saint Vrain 230 kV	P1	3ph	Fort Saint Vrain – Isabelle 230 kV line 1	5.0	Stable	Stable
11	Fort Saint Vrain 230 kV	P1	3ph	Fort Saint Vrain – Spindle 230 kV line 1	5.0	Stable	Stable
12	Fort Saint Vrain 230 kV	P1	3ph	Fort Saint Vrain – Keenesburg 230 kV line 1	5.0	Stable	Stable
13	Fort Saint Vrain 230 kV	P1	3ph	Fort Saint Vrain – Long Peak 230 kV line 1	5.0	Stable	Stable
14	Fort Saint Vrain 230 kV	P1	3ph	Fort Saint Vrain – Fordham 230 kV line 1	5.0	Stable	Stable

### 4.8.3 Short-Circuit Analysis Results

Fault Current at the POI is as follows:

Table 10 – Short-Circuit Parameters at GI-2021-2 POI

	Before the Cluster addition	After the Cluster addition
<b>Three Phase</b>		
Three Phase Current	42759 A	42861 A
Positive Sequence Impedance	0.21780 + j3.10344 ohms	0.21780 + j3.10344 ohms
Negative Sequence Impedance	0.25164 + j3.09294 ohms	0.25164 + j3.09294 ohms
Zero Sequence Impedance	0.30528 + j2.71817 ohms	0.30533 + j2.71804 ohms
<b>Phase-to-Ground</b>		
Single Line to Ground Current	44517 A	44459 A
Positive Sequence Impedance	0.21780 + j3.10344 ohms	0.21780 + j3.10344 ohms
Negative Sequence Impedance	0.25164 + j3.09294 ohms	0.25164 + j3.09294 ohms
Zero Sequence Impedance	0.30528 + j2.71817 ohms	0.30533 + j2.71804 ohms

**Table 11 – Short-Circuit Parameters at GI-2021-3 POI**

	<b>Before the Cluster addition</b>	<b>After the Cluster addition</b>
<b>Three Phase</b>		
Three Phase Current	42759 A	42861 A
Positive Sequence Impedance	0.21780 + j3.10344 ohms	0.21780 + j3.10344 ohms
Negative Sequence Impedance	0.25164 + j3.09294 ohms	0.25164 + j3.09294 ohms
Zero Sequence Impedance	0.30528 + j2.71817 ohms	0.30533 + j2.71804 ohms
<b>Phase-to-Ground</b>		
Single Line to Ground Current	44517 A	44459 A
Positive Sequence Impedance	0.21780 + j3.10344 ohms	0.21780 + j3.10344 ohms
Negative Sequence Impedance	0.25164 + j3.09294 ohms	0.25164 + j3.09294 ohms
Zero Sequence Impedance	0.30528 + j2.71817 ohms	0.30533 + j2.71804 ohms

**Table 12 – Short-Circuit Parameters at GI-2021-6 POI**

	<b>Before the Cluster addition</b>	<b>After the Cluster addition</b>
<b>Three Phase</b>		
Three Phase Current	21608 A	21632 A
Positive Sequence Impedance	0.64458 + j6.14490 ohms	0.64458 + j6.14490 ohms
Negative Sequence Impedance	0.68850 + j6.12485 ohms	0.68850 + j6.12485 ohms
Zero Sequence Impedance	3.37071 + j13.5513 ohms	1.84617 + j9.92182 ohms
<b>Phase-to-Ground</b>		
Single Line to Ground Current	15173 A	18106 A
Positive Sequence Impedance	0.64458 + j6.14490 ohms	0.64458 + j6.14490 ohms
Negative Sequence Impedance	0.68850 + j6.12485 ohms	0.68850 + j6.12485 ohms
Zero Sequence Impedance	3.37071 + j13.5513 ohms	1.84617 + j9.92182 ohms

#### **4.8.4 Summary of Northern Colorado Study Pocket Analysis**

The transient stability analysis did not identify any Network Upgrades. The Phase 1 steady-state analysis did not identify any network upgrades.

Based on the analysis performed in the Phase 1 and Phase 2 studies, the results of the GI-2021-2, GI-2021-3, and GI-2020-6 are as follows:

- The NRIS identified for GI-2021-6 is 199 MW.

The maximum allowed output of the ERIS GIRs without requiring additional Network Upgrades is:

- GI-2021-2 is 0 MW
- GI-2021-3 is 0 MW

Energy Resource Interconnection Service, when using the existing firm or non-firm capacity of the Transmission System on an “as available” basis is:

- GI-2021-2 is 49 MW
- GI-2021-3 is 35 MW

The studies did not identify any impacts to the Affected Systems.

## 5.0 Cost Estimates and Assumptions

There are three types of costs identified in the study:

- Transmission Provider’s Interconnection Facilities which are directly assigned to each GIR
- Station Network Upgrades, which are allocated to each GIR connecting to that station on a per-capita basis per Section 4.2.4(a) of the LGIP
- All other Network Upgrades which are allocated by the proportional impact per Section 4.2.4(b) of the LGIP

### 5.1 Total Cost of Transmission Provider’s Interconnection Facilities (TPIF)

The total cost of Transmission Provider’s Interconnection Facilities (TPIF) for each POI and each GIRs cost assignment are given in Table 13.

**Table 13 – Total cost of Transmission Provider’s Interconnection Facilities by GIR**

<b>GIR</b>	<b>POI</b>	<b>Total Cost (million)</b>
GI-2021-1	Comanche 230 kV Substation	\$1.272
GI-2021-2	Fort Saint Vrain 230 kV Substation	\$0.050
GI-2021-3	Fort Saint Vrain 230 kV Substation	\$0.050
GI-2021-4	GI-2021-4 69 kV Switching Station	\$2.174
GI-2021-6	GI-2021-6 230 kV Switching Station	\$1.557
GI-2021-9	Tundra 345 kV Switching Station	\$1.880

Table 14 through Table 19 specify each GIR’s Transmission Provider’s Interconnection Facilities and the corresponding costs.

**Table 14 – GI-2021-1 Transmission Provider’s Interconnection Facilities**

<b>Element</b>	<b>Description</b>	<b>Cost Est. (million)</b>
PSCo’s Comanche 230 kV Substation	Interconnection Customer to tap at the Comanche 230 kV Substation. The new equipment includes: <ul style="list-style-type: none"> <li>• (1) 230 kV deadend structure</li> <li>• (1) 230 kV monopole deadend transition structure</li> <li>• (3) 230 kV surge arresters</li> <li>• (1) 230 kV 2,000 A disconnect switch</li> <li>• (3) 230 kV CT/PT combination metering units</li> <li>• Fiber communication equipment</li> <li>• Station controls</li> <li>• Associated electrical equipment, bus, wiring and grounding</li> <li>• Associated foundations and structures</li> <li>• Associated transmission line communications, fiber, relaying and testing.</li> </ul>	\$1.172
	Siting and Land Rights support for siting studies, land and ROW acquisition and construction	\$0.100
<b>Total Cost Estimate for Interconnection Customer-Funded, PSCo-Owned Interconnection Facilities</b>		<b>\$1.272</b>
<b>Time Frame</b>	<b>Site, design, procure and construct</b>	<b>18 Months</b>

**Table 15 – GI-2021-2 Transmission Provider’s Interconnection Facilities**

<b>Element</b>	<b>Description</b>	<b>Cost Est. (million)</b>
PSCo’s Ft. St. Vrain Unit #2	Confirmation testing of incremental increase in generation output due to a plant equipment upgrade	\$0.050
<b>Total Cost Estimate for Interconnection Customer-Funded, PSCo-Owned Interconnection Facilities</b>		<b>\$0.050</b>
<b>Time Frame</b>	<b>Site, design, procure and construct</b>	<b>6 Months</b>

**Table 16 – GI-2021-3 Transmission Provider’s Interconnection Facilities**

<b>Element</b>	<b>Description</b>	<b>Cost Est. (million)</b>
PSCo’s Ft. St. Vrain Unit #3	Confirmation testing of incremental increase in generation output due to a plant equipment upgrade	\$0.050
<b>Total Cost Estimate for Interconnection Customer-Funded, PSCo-Owned Interconnection Facilities</b>		<b>\$0.050</b>
<b>Time Frame</b>	<b>Site, design, procure and construct</b>	<b>6 Months</b>

**Table 17 – GI-2021-4 Transmission Provider’s Interconnection Facilities**

<b>Element</b>	<b>Description</b>	<b>Cost Est. (million)</b>
PSCo’s GI-2021-4 69 kV Switching Station	Interconnection Customer to tap at the GI-2021-4 69 kV Switching Station. The new equipment includes: <ul style="list-style-type: none"> <li>• (2) 69 kV deadend structures</li> <li>• (1) 69 kV circuit breaker</li> <li>• (3) 115 kV surge arresters</li> <li>• (3) 69 kV disconnect switches</li> <li>• (3) CT/PT combination metering units</li> <li>• Fiber communication equipment</li> <li>• Station controls</li> <li>• Associated electrical equipment, bus, wiring and grounding</li> <li>• Associated foundations and structures</li> <li>• Associated transmission line communications, fiber, relaying and testing.</li> </ul>	\$2.074
	Siting and Land Rights support for siting studies, land and ROW acquisition and construction	\$0.100
<b>Total Cost Estimate for Interconnection Customer-Funded, PSCo-Owned Interconnection Facilities</b>		<b>\$2.174</b>
<b>Time Frame</b>	<b>Site, design, procure and construct</b>	<b>36 Months</b>

**Table 18 – GI-2021-6 Transmission Provider’s Interconnection Facilities**

<b>Element</b>	<b>Description</b>	<b>Cost Est. (million)</b>
PSCo’s GI-2021-6 230 kV Switching Station	Interconnection Customer to tap at the GI-2021-6 230 kV Switching Station. The new equipment includes: <ul style="list-style-type: none"> <li>• (1) 230 kV deadend structure</li> <li>• (3) 230 kV surge arresters</li> <li>• (1) 230 kV 3,000 A disconnect switch</li> <li>• (3) CT/PT combination metering units</li> <li>• Fiber communication equipment</li> <li>• Station controls</li> <li>• Associated electrical equipment, bus, wiring and grounding</li> <li>• Associated foundations and structures</li> <li>• Associated transmission line communications, fiber, relaying and testing.</li> </ul>	\$1.457
	Siting and Land Rights support for siting studies, land and ROW acquisition and construction	\$0.100
<b>Total Cost Estimate for Interconnection Customer-Funded, PSCo-Owned Interconnection Facilities</b>		<b>\$1.557</b>
<b>Time Frame</b>	<b>Site, design, procure and construct</b>	<b>36 Months</b>

**Table 19 – GI-2021-9 Transmission Provider’s Interconnection Facilities**

<b>Element</b>	<b>Description</b>	<b>Cost Est. (million)</b>
PSCo’s Tundra 345 kV Switching Station	Interconnection Customer to tap at the Tundra 345 kV Switching Station. The new equipment includes: <ul style="list-style-type: none"> <li>• (1) 345 kV deadend structure</li> <li>• (3) 345 kV surge arresters</li> <li>• (1) 345 kV 3,000 A disconnect switch</li> <li>• (3) CVTs</li> <li>• (3) CTs</li> <li>• Fiber communication equipment</li> <li>• Station controls</li> <li>• Associated electrical equipment, bus, wiring and grounding</li> <li>• Associated foundations and structures</li> <li>• Associated transmission line communications, fiber, relaying and testing.</li> </ul>	\$1.780
	Siting and Land Rights support for siting studies, land and ROW acquisition and construction	\$0.100
<b>Total Cost Estimate for Interconnection Customer-Funded, PSCo-Owned Interconnection Facilities</b>		<b>\$1.880</b>
<b>Time Frame</b>	<b>Site, design, procure and construct</b>	<b>18 Months</b>

## 5.2 Total Cost of Station Network Upgrades

The total cost of Station Network Upgrades for each POI and each GIRs cost assignment are given in Table 20.

**Table 20 – Total Cost of Station Network Upgrades by POI**

POI	Total Cost (million)	GIRs Sharing the POI	Allocation
Comanche 230 kV Substation	\$1.495	GI-2021-1	100%
Fort Saint Vrain 230 kV Substation	\$0	GI-2021-2 & GI-2021-3	N/A
GI-2021-4 69 kV Switching Station	\$11.439	GI-2021-4	100%
GI-2021-6 230 kV Switching Station	\$19.894	GI-2021-6	100%
Tundra 345 kV Switching Station	\$3.009	GI-2021-9	100%

The details of the Station Network Upgrades required at the Comanche 230 kV Substation POI are shown in Table 21. These costs are 100% assigned to GI-2021-1.

**Table 21 – Station Network Upgrades – Comanche 230 kV Substation**

Element	Description	Cost Est. (million)
PSCo's Comanche 230 kV Substation	Expand Comanche 230 kV Substation to accommodate GI-2021-1. The new equipment includes: <ul style="list-style-type: none"> <li>• (1) 230 kV deadend structure</li> <li>• (1) 230 kV 3,000 A circuit breakers</li> <li>• (1) 230 kV 3,000 A disconnect switch</li> <li>• Station controls and wiring</li> <li>• Associated foundations and structures</li> </ul>	\$1.157
PSCo's Comanche 230 kV Substation	Upgrade required communication in the EEE at the Comanche 230 kV Substation	\$0.238
	Siting and Land Rights support for substation construction	\$0.100
<b>Total Cost Estimate for PSCo-Funded, PSCo-Owned Interconnection Facilities</b>		<b>\$1.495</b>
<b>Time Frame</b>	<b>Site, design, procure and construct</b>	<b>18 Months</b>



The total cost and details of the Station Network Upgrades required at the GI-2021-4 69 kV Switching Station tapping the Romeo – Old40Tap 69 kV line are shown in Table 22. These Station Network Upgrade costs are 100% assigned to GI-2021-4. Construction of GI-2021-4 69 kV Switching Station may be impacted by the availability of outages on the Romeo – Old40Tap 69 kV radial line.

**Table 22 – Station Network Upgrades – GI-2021-4 69 kV Switching Station**

<b>Element</b>	<b>Description</b>	<b>Cost Est. (million)</b>
PSCo's GI-2021-4 69 kV Switching Station	Install a new GI-2021-4 69 kV Switching Station on the Romeo – Old40Tap 69 kV 6914 line. The new equipment includes: <ul style="list-style-type: none"> <li>• (4) 69 kV deadend structures</li> <li>• (2) 69 kV circuit breakers</li> <li>• (4) 69 kV disconnect switches</li> <li>• (6) 115 kV surge arresters</li> <li>• (1) Electrical Equipment Enclosure (EEE)</li> <li>• Station controls and wiring</li> <li>• Associated foundations and structures</li> </ul>	\$9.437
PSCo's GI-2021-4 69 kV Switching Station	Install required communication in the EEE at the GI-2021-4 69 kV Switching Station	\$0.620
PSCo's Alamosa Switching Station	Remote end upgrades for 6914 at Alamosa 69 kV Switching Station	\$0.541
PSCo's Alamosa Terminal Substation	Remote end upgrades for 6914 at Alamosa 69 kV Terminal Substation	\$0.409
	Siting & Land Rights support for substation construction	\$0.432
<b>Total Cost Estimate for PSCo-Funded, PSCo-Owned Interconnection Facilities</b>		<b>\$11.439</b>
<b>Time Frame</b>	<b>Site, design, procure and construct</b>	<b>36 Months</b>

The total cost and details of the Station Network Upgrades required at the GI-2021-6 230 kV Switching Station tapping the Green Valley – Sky Ranch 230 kV line are shown in Table 23. These Station Network Upgrade costs are 100% assigned to GI-2021-6.

**Table 23 – Station Network Upgrades – GI-2021-6 230 kV Switching Station**

<b>Element</b>	<b>Description</b>	<b>Cost Est. (million)</b>
PSCo's GI-2021-6 230 kV Switching Station	Install a new GI-2021-6 230 kV Switching Station on the Green Valley – Sky Ranch 230 kV 5275 line. The new equipment includes: <ul style="list-style-type: none"> <li>• (8) 230 kV deadend structures</li> <li>• (3) 230 kV 3,000 A circuit breakers</li> <li>• (8) 230 kV 3,000 A disconnect switches</li> <li>• (6) 230 kV surge arresters</li> <li>• (6) 230 kV CCVTs</li> <li>• (2) 230 kV SSVTs</li> <li>• (1) Electrical Equipment Enclosure (EEE)</li> <li>• (2) wave traps</li> <li>• Station controls and wiring</li> <li>• Associated foundations and structures</li> </ul>	\$15.051
PSCo's GI-2021-6 230 kV Switching Station	Install required communication in the EEE at the GI-2021-6 230 kV Switching Station	\$0.884
PSCo's Sky Ranch 230 kV Substation	Remote end upgrades for 5275 at Sky Ranch 230 kV Substation	\$1.268
PSCo's Green Valley 230 kV Substation	Remote end upgrades for 5275 at Green Valley 230 kV Substation	\$1.302
	Siting & Land Rights support for substation construction	\$1.389
<b>Total Cost Estimate for PSCo-Funded, PSCo-Owned Interconnection Facilities</b>		<b>\$19.894</b>
<b>Time Frame</b>	<b>Site, design, procure and construct</b>	<b>36 Months</b>

The estimated total cost and details of the Station Network Upgrades required at the Tundra 345 kV Switching Station are shown in Table 24. These Station Network Upgrade costs are 100% assigned to GI-2021-9. Tundra is a new station built for GI-2018-24 in the Transitional Cluster. As noted in the Transitional Cluster study report, construction of the Tundra Switching Station requires a CPCN. The interconnection of GI-2021-9 is impacted by the Tundra CPCN approval and schedule.

**Table 24 – Station Network Upgrades – Tundra 345 kV Substation**

<b>Element</b>	<b>Description</b>	<b>Cost Est. (million)</b>
PSCo's Tundra 345 kV Switching Station	Expand Tundra 345 kV Switching Station to accommodate GI-2021-9. The new equipment includes: <ul style="list-style-type: none"> <li>• (1) 345 kV deadend structure</li> <li>• (1) 345 kV 3,000 A circuit breaker</li> <li>• (4) 345 kV 3,000 A disconnect switches</li> <li>• Station controls and wiring</li> <li>• Associated foundations and structures</li> </ul>	\$2.909
	Siting and Land Rights support for substation construction	\$0.100
<b>Total Cost Estimate for PSCo-Funded, PSCo-Owned Interconnection Facilities</b>		<b>\$3.009</b>
<b>Time Frame</b>	<b>Site, design, procure and construct</b>	<b>18 Months</b>

## 5.3 Summary of Generation Interconnection Costs

### 5.3.1 For GI-2021-1

The total cost of the required system improvements for GI-2021-1 to interconnect at the Comanche 230 kV Substation is **\$2.767 million**.

- **The cost of Transmission Provider's Interconnection Facilities is \$1.272 million** (Table 14)
- **The cost of Station Network Upgrades is \$1.495 million** (Table 21)
- **The cost of System Network Upgrades is \$0**

Figure 3 is a conceptual one-line of the GI-2021-1 POI at the Comanche 230 kV Substation.

The list of improvements required to accommodate the interconnection of GI-2021-1 are given in Table 14 and Table 21. System improvements are subject to revision as a more detailed and refined design is produced.

### 5.3.2 For GI-2021-2

The total cost of the required system improvements to allow GI-2021-2 expansion at the Fort Saint Vrain #2 generator is \$0.05 million.

- **The cost of Transmission Provider's Interconnection Facilities is \$0.05 million** (Table 15)
- **The cost of Station Network Upgrades is \$0**
- **The cost of System Network Upgrades is \$0**

The list of improvements required to accommodate the interconnection of GI-2021-2 are given in Table 15. System improvements are subject to revision as a more detailed and refined design is produced.

### 5.3.3 For GI-2021-3

The total cost of the required system improvements to allow GI-2021-3 expansion at the Fort Saint Vrain #3 generator is \$0.05 million.

- **The cost of Transmission Provider's Interconnection Facilities is \$0.05 million** (Table 16)

- **The cost of Station Network Upgrades is \$0**
- **The cost of System Network Upgrades is \$0**

The list of improvements required to accommodate the interconnection of GI-2021-3 are given in Table 16. System improvements are subject to revision as a more detailed and refined design is produced.

### **5.3.4 For GI-2021-4**

The total cost of the required system improvements for GI-2021-4 to interconnect on the Romeo – Old40Tap 69 kV line is **\$13.613 million**.

- **The cost of Transmission Provider’s Interconnection Facilities is \$2.174 million** (Table 17)
- **The cost of Station Network Upgrades is \$11.439 million** (Table 22)
- **The cost of System Network Upgrades is \$0**

Figure 4 is a conceptual one-line of the GI-2021-4 69 kV Switching Station tapping the Romeo – Old40Tap 69 kV line.

The list of improvements required to accommodate the interconnection of GI-2021-4 are given in Table 17 and Table 22. System improvements are subject to revision as a more detailed and refined design is produced.

### **5.3.5 For GI-2021-6**

The total cost of the required system improvements to interconnect GI-2021-6 on the Green Valley – Sky Ranch 230 kV line is **\$21.451 million**.

- **The cost of Transmission Provider’s Interconnection Facilities is \$1.557 million** (Table 18)
- **The cost of Station Network Upgrades is \$19.894 million** (Table 23)
- **The cost of System Network Upgrades is \$0**

Figure 5 is a conceptual one-line of the GI-2021-6 230 kV Switching Station.

The list of improvements required to accommodate the interconnection of GI-2020-16 are given in Table 18 and Table 23. A CPCN will be required to construct the GI-2021-6 230 kV Switching Station. The estimated time frame for regulatory activities and to site, design, procure and

construct the interconnection facilities (entire project) is approximately 36 months after authorization to proceed has been obtained.

System improvements are subject to revision as a more detailed and refined design is produced.

### **5.3.6 For GI-2021-9**

The total cost of the required system improvements to interconnect GI-2021-9 at the Tundra 345 kV Switching Station is **\$4.889 million**.

- **The cost of Transmission Provider's Interconnection Facilities is \$1.880 million** (Table 19)
- **The cost of Station Network Upgrades is \$3.009 million** (Table 24)
- **The cost of System Network Upgrades is \$0**

Figure 6 is a conceptual one-line of the GI-2021-9 POI at the Tundra 345 kV Substation.

The list of improvements required to accommodate the interconnection of GI-2021-9 at the Tundra 345 kV Switching Station are given in Table 19 and Table 24. System improvements are subject to revision as a more detailed and refined design is produced.

## **5.4 Cost Estimate Assumptions**

The cost estimates provided in this Phase 2 Study Report are based on the following assumptions:

- The cost estimates are in 2022 dollars with an escalation percentage and contingencies applied to the cost estimates.
- The cost estimates do not include an Allowance for Funds Used During Construction (AFUDC).
- The estimated costs include all applicable labor and overheads associated with the siting, engineering, design, and construction of the PSCo facilities to facilitate interconnection.
- The estimated costs do not include the cost for any Interconnection Customer owned equipment and associated design and engineering.
- Labor is estimated at straight time only, no overtime work is included.
- Lead times for materials were considered for the schedule.
- No costs for retail load metering are included in these estimates.
- PSCo (or its Contractor) will perform all construction, wiring, testing, and commissioning for PSCo owned and maintained facilities.

- A CPCN may be required for the construction of the Interconnection Facilities and Station Network Upgrades. The expected time to obtain a CPCN approval is 18 months.
- The estimated time to permit, design, procure and construct the interconnection facilities is approximately 18 months after authorization to proceed (post CPCN) has been obtained.
- Interconnection Customer will install two (2) redundant fiber optic circuits into the Transmission Provider's substation as part of its interconnection facilities construction scope.
- Power Quality Metering (PQM) will be required on the Interconnection Customer's generation tie-line terminating into the POI.
- The Interconnection Customer will be required to design, procure, install, own, operate and maintain a Load Frequency/Automated Generation Control (LF/AGC) RTU at their Interconnection Customer substation. PSCo will be provided with indications, readings, and data from the LF/AGC RTU.

## **6.0 Summary of Generation Interconnection Service**

The Interconnection Customer is required to design their inverter-based resource (wind, solar or hybrid) Generating Facility to eliminate or mitigate potential for inverter or plant controller instability and/or controller response interactions with the plant controllers of existing inverter-based resource (wind, solar or hybrid) Generating Facility(ies).

This study only evaluated Interconnection Service of GIRs in 3DISIS-2021-001 and Interconnection Service in and itself does not convey transmission service.

### **6.1 GI-2021-1**

The total cost of the upgrades required to interconnect GI-2021-1 at the Comanche 230 kV Substation for ERIS is \$2.767 million (Table 14 and Table 21).

Maximum allowable output of GI-2021-1 without requiring additional Network Upgrades is 0 MW.

ERIS of GI-2021-1 is 200 MW when using the existing firm or non-firm capacity of the Transmission System on an “as available” basis.

### **6.2 GI-2021-2**

The total cost of the upgrades required to allow GI-2021-2 expansion at the Fort Saint Vrain #2 generator for ERIS is \$0.05 million (Table 15).

Maximum allowable output of GI-2021-2 without requiring additional Network Upgrades is 0 MW.

ERIS of GI-2021-2 is 49 MW when using the existing firm or non-firm capacity of the Transmission System on an “as available” basis.

### **6.3 GI-2021-3**

The total cost of the upgrades required to allow GI-2021-3 expansion at the Fort Saint Vrain #3 generator for ERIS is \$0.05 million (Table 16).

Maximum allowable output of GI-2021-3 without requiring additional Network Upgrades is 0 MW.

ERIS of GI-2021-3 is 35 MW when using the existing firm or non-firm capacity of the Transmission System on an “as available” basis.



## **6.4 GI-2021-4**

The total cost of the upgrades required to interconnect GI-2021-4 on the Romeo – Old40Tap 69 kV line for NRIS is \$13.613 million (Table 17 and Table 22).

Network Resource Interconnection of GI-2021-4 is 42 MW.

The output of the GI-2021-4 hybrid Generating Facility will be limited to 42 MW at the POI using centralized power plant controller. The GIR output will also be monitored by PSCo operations. Additional monitoring and control requirements will be added to the LGIA to ensure the Interconnection Service amount is not exceeded. The charging of Battery Energy Storage in this hybrid Generating Facility will occur using the PV Solar generation output – hence no grid charging was studied.

## **6.5 GI-2021-6**

The total cost of the upgrades required to interconnect GI-2021-6 on the Green Valley – Sky Ranch 230 kV line for NRIS is \$21.451 million (Table 18 and Table 23).

Network Resource Interconnection of GI-2021-6 is 199 MW.

The output of the GI-2021-6 hybrid Generating Facility will be limited to 199 MW at the POI using centralized power plant controller. The GIR output will also be monitored by PSCo operations. Additional monitoring and control requirements will be added to the LGIA to ensure the Interconnection Service amount is not exceeded. The charging of Battery Energy Storage in this hybrid Generating Facility will occur using the PV Solar generation output – hence no grid charging was studied.

A CPCN is needed for the expansion of the construction of the GI-2021-6 230 kV Switching Station. The estimated time frame for regulatory activities and to site, design, procure and construct the interconnection facilities is approximately 36 months after authorization to proceed has been obtained. Any delays in obtaining the CPCN may delay the COD of GI-2021-6.

## **6.6 GI-2021-9**

The total cost of the upgrades required to interconnect GI-2021-9 at the Tundra 345 kV Switching Station for ERIS is \$4.889 million (Table 19 and Table 24).

Maximum allowable output of GI-2021-9 without requiring additional Network Upgrades is 0 MW.

ERIS of GI-2021-9 is 199 MW when using the existing firm or non-firm capacity of the Transmission System on an “as available” basis.

## 7.0 Contingent Facilities

The following is the list of the unbuilt Interconnection Facilities and Network Upgrades upon which the costs, timing, and study findings of the 3DISIS-2021-001 are dependent, and if delayed or not built, could cause a need for re-studies of the Interconnection Service or a reassessment of the Interconnection Facilities and/or Network Upgrades and/or costs and timing. The individual GIR's maximum allowable output may be decreased if these Contingent Facilities are not in-service.

Each unbuilt facility was studied as a potential contingent facility independently. The unbuilt facilities in each study pocket were reverted to the pre-project topology, and the resultant worst-case overloads were reported in Appendix B. The study generators' DFAX were calculated for the worst-case overloads. If reverting the unbuilt facility causes an overload, with >1% study generator DFAX, the unbuilt facility will be identified as a contingent facility for that study generator.

**GI-2021-1 and GI-2021-9:** The Contingent Facilities identified for these GIRs are:

- The following unbuilt transmission projects modeled in the study:
  - 1) Briargate South 115/230 kV transformer project tapping the Cottonwood – Fuller 230 kV line – ISD 2023
  - 2) Monument – Flying Horse 115 kV Series Reactor – ISD 2022
  - 3) Fuller 230/115 kV Transformer #2 – ISD 2023
  - 4) Loop existing Comanche – Midway 230 kV line ckt #2 into Mirasol 230 kV Substation – ISD 2023
  - 5) Greenwood – Arapahoe – Denver Terminal 230 kV line – ISD 2022
  - 6) Additional (second) Waterton 345/230 kV Transformer – ISD 2024
  - 7) Upgrade Midway 230/115 kV Transformer to 280 MVA rating – ISD 2024
  - 8) Tundra 345 kV Switching Station as POI for GI-2021-9 – ISD 2022.
- Additional Contingent Facilities identified for GI-2021-1 and GI-2021-9 include the Station and System Network Upgrades and Interconnection Facilities identified in Table 14, Table 19, Table 21, and Table 24, respectively.

Tables B-1 through B-7, included in Appendix B, summarize the worst-case branch overloads when an unbuilt facility is excluded from the Study Case.

**GI-2021-4:** The Contingent Facilities identified for this GIR are:

- The following unbuilt transmission projects modeled in the study:

- 1) Upgrade Antonito – Romeo – Old40Tap – Alamosa Terminal – Alamosa Switchyard 69 kV line rating to 143 MVA – ISD 2023
- 2) Upgrade Villa Grove – Poncha 69 kV line rating to 73 MVA – ISD 2021
- 3) Upgrade Poncha – Sargent – San Luis Valley 115 kV line rating to 120 MVA – ISD 2021

- Additional Contingent Facilities identified for GI-2021-4 include the Station and Network Upgrades and Interconnection Facilities identified in Table 17 and Table 22, respectively.

Tables B-8 through B-10, included in Appendix B, summarize the worst-case branch overloads when an unbuilt facility is excluded from the Study Case.

**GI-2021-2, GI-2021-3, and GI-2021-6:** There are no unbuilt facilities modeled in the Northern Colorado study pocket analysis. The Contingent Facilities identified for GI-2021-2, GI-2021-3, and GI-2021-6 include the Station and Network Upgrades and Interconnection Facilities identified in Table 15, Table 16, Table 18, and Table 23 respectively.

**Short-Circuit Contingent Breakers:** Section 4.7 of the Business Practice Manual states that “All future breaker replacements which have a short-circuit current contribution from the GIR are contingent facilities”. A series of fault studies were run to determine which of these breakers had any contribution from any of the GIRs in the DISIS. Results are shown in Table B-11, included in Appendix B.

## 8.0 Conceptual POI One-Line Diagrams of 3DISIS-2021-001 GIRs

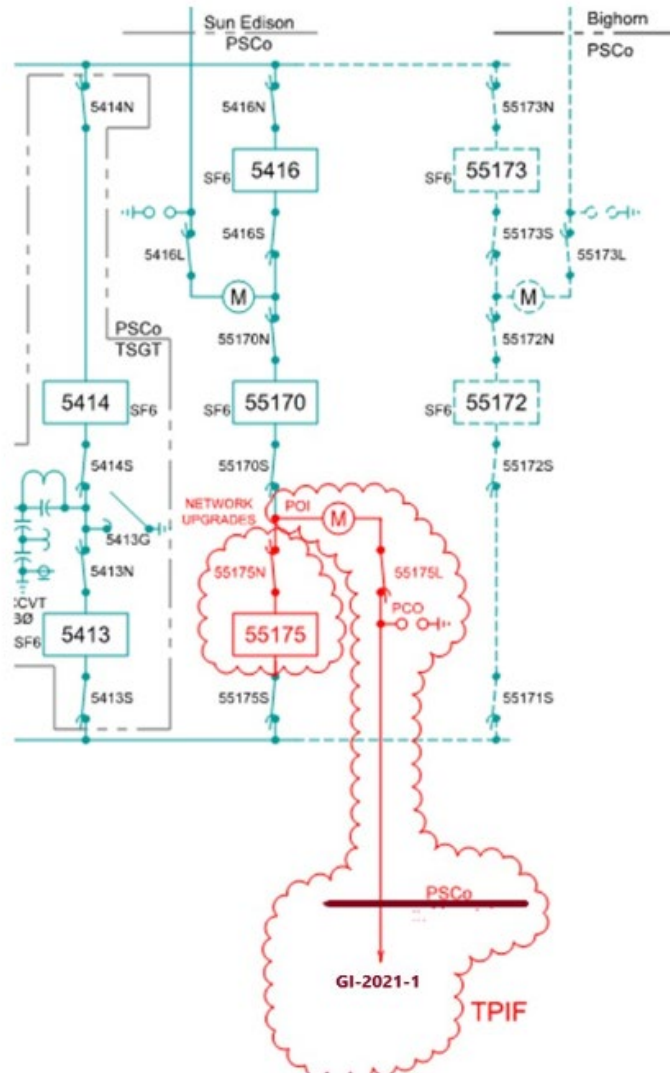

Figure 3 – Preliminary One-line of the GI-2021-1 POI at the Comanche 230 kV Substation



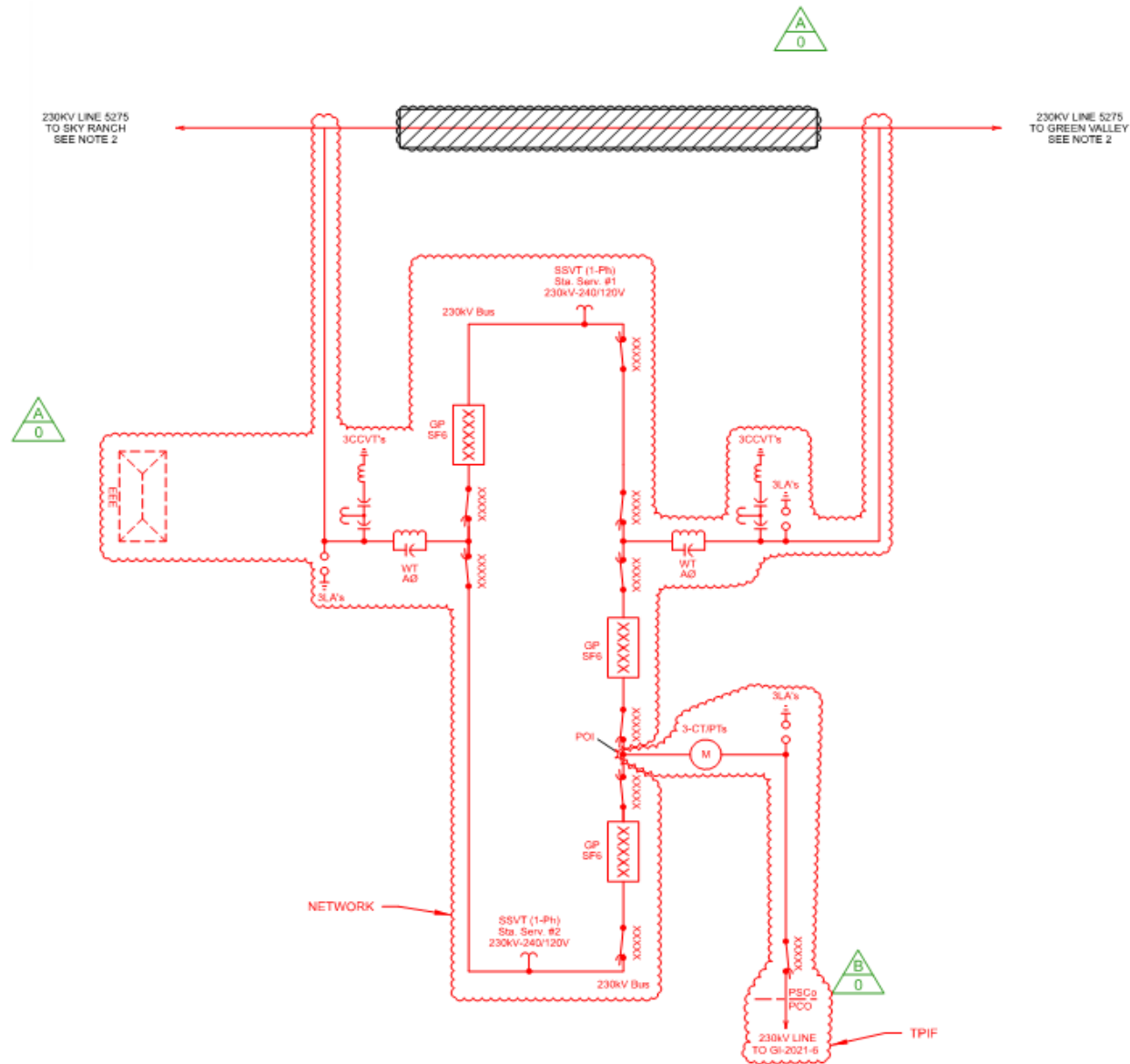

Figure 5 – Preliminary One-line of the GI-2021-6 230 kV Switching Station tapping the Green Valley – Sky Ranch 230 kV line

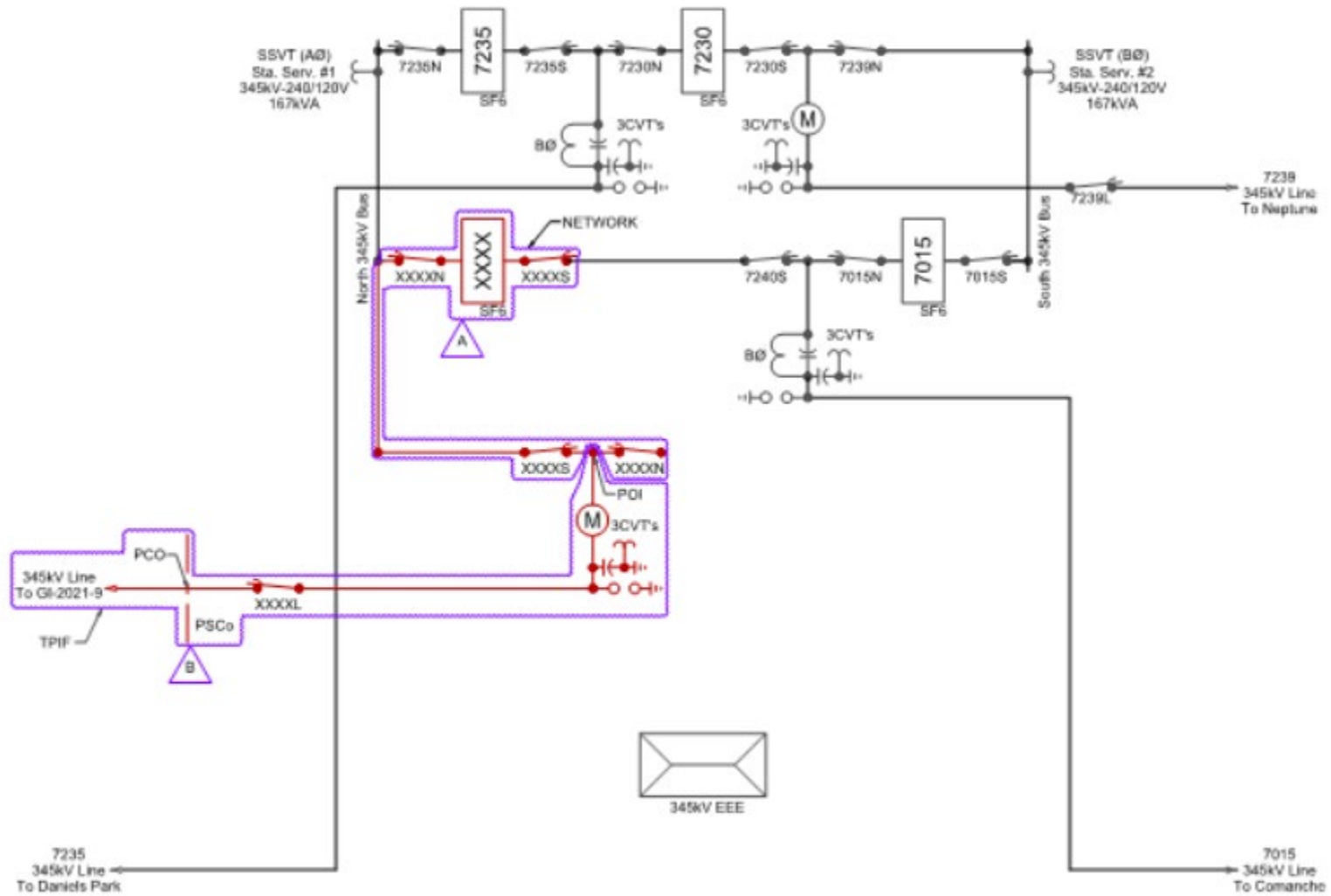



Figure 6 – Preliminary One-line of the GI-2021-9 POI at the Tundra 345 kV Substation



### 9.0 Appendices

Appendix A: Transient Stability Plots	 Appendix_A Transient Stability Plots
Appendix B: Contingent Facilities' Study Results	 Appendix_B Contingent Facilities